

## Specifications

### Min. Load @ 20 psi

Vertical Natural Frequency	2.3 Hz
Isolation Efficiency @ 5 Hz	52%
Isolation Efficiency @ 10 Hz	83%
Horizontal Natural Frequency	2.9 Hz
Isolation Efficiency @ 5 Hz	40%
Isolation Efficiency @ 10 Hz	92%

### Max. Load @ 80 psi

Vertical Natural Frequency	2.1 Hz
Isolation Efficiency @ 5 Hz	70%
Isolation Efficiency @ 10 Hz	91%
Horizontal Natural Frequency	1.8 Hz
Isolation Efficiency @ 5 Hz	81%
Isolation Efficiency @ 10 Hz	95%

Net Load Capacity @ 80 psi	
2212-02/03	450 lbs. (204 kg)
All Others	200 lbs. (91 kg)

Finish:	
Standard Class 10	Linear White Polyurethane White Epoxy Powder Coat

### Approximate Shipping Weight:

2210-01-xx	157 lbs.	(72 kg)
2210-04-xx	145 lbs.	(66 kg)
2212-01-xx	157 lbs.	(72 kg)
2212-02-xx	210 lbs.	(96 kg)
2212-03-xx	245 lbs.	(112 kg)
2212-04-xx	145 lbs.	(66 kg)
2214-01-xx	157 lbs.	(72 kg)

Note: Typical performance efficiencies are for microdisturbances

## Applications

(Partial List)

Atomic Force Microscopes, Microhardness Testers, Profilometers, Balances, Audio Equipment, and other Precision Measuring and Testing Equipment.



## Dimensions

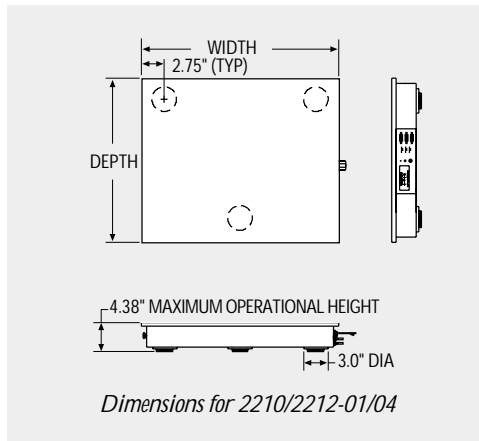

Typical OEM application.  
Photo courtesy of Warner Instruments.

## Dimensions

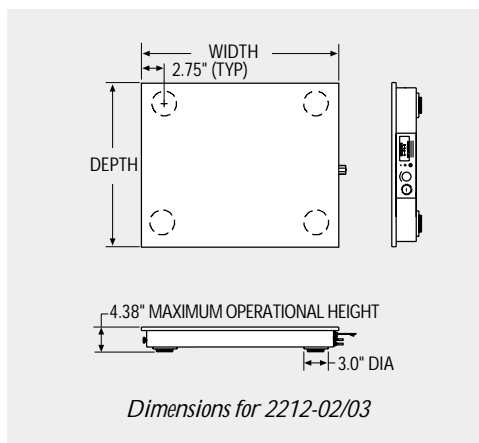

## Dimensions

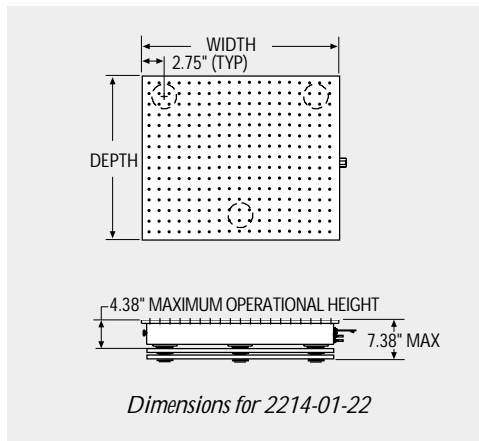

## Ordering Information

22   -   -

### Configuration

- 10 = Passive-Air
- 12 = Active-Air
- 14\* = Active-Air with enhanced horizontal isolation

### Tabletop Size (depth x width)

- 01 = 20" x 24" (508mm x 609mm) All
- 02 = 24" x 30" (609mm x 762mm) 2212 only
- 03\* = 24" x 36" (609mm x 914mm) 2212 only
- 04 = 16" x 19" (406mm x 482mm) 2210 / 2212 only

\*Special Order

### Top Description

- 11 = White plastic laminate
- 12 = Ferromagnetic stainless steel
- 13 = Black plastic laminate
- 14 = White antistatic laminate
- 22 = Ferromagnetic stainless steel with 1/4"-20 x 1" centers (SPILLPRUF)
- 25 = Ferromagnetic stainless steel with 1/4"-20 x 0.5" centers (SPILLPRUF) MaxxAlign
- 32 = Ferromagnetic stainless steel with M6 holes x 25mm centers (SPILLPRUF)
- 35 = Ferromagnetic stainless steel with M6 holes x 12.5mm centers (SPILLPRUF) MaxxAlign

### Optional Accessories

- Hand Pump = HP
- Portable Air Compressor = PAC